

30W Constant Voltage Slim-US Series

US-30-XX LR1



Approve



Features

- Class II, SELV, independent
- Input Voltage 220-240VAC
- Protections: SCP/OLP/OVP/OTP
- Power Factor >0.95
- Efficiency $\geq 83\%$
- 5 years warranty

Applications

- LED strips
- kitchen light
- bathroom light

Description

US-30-XX LR1 is a 30W constant voltage LED driver that operates from 198-264Vac input with 12V or 24V output voltage. With it's slim dimensions from 261 x 30x 17mm it is easy to integrate in LED strips, kitchen light and bathroom light products. To ensure trouble-free operation, protection is provided against output short circuit, over Load and over temperature.

Model code

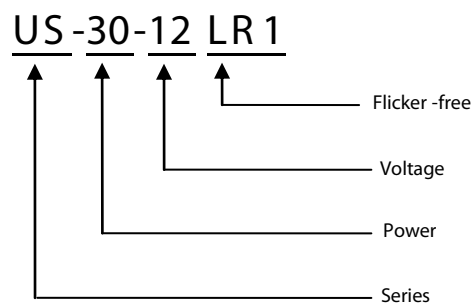

30W Constant Voltage Slim-US Series

US-30-XX LR1

■ Specification

Input	Rated input voltage	220-240VAC	
	Range of input voltage	198-264VAC	
	Range of input voltage(VDC)	176-250VDC	
	Frequency(Hz)	0/50/60 Hz	
	Power Factor	> 0.95@Full load, 230VAC	
	Input Current max	0.24A MAX. @Full Load,198VAC	
	Start-up time	< 0.5S	
	Unload Power Consumption	≤0.5W	
	Inrush Current	20A Max. @ Full Load, 230VAC	
	THD	< 8% Typ. @Full load, 230VAC	
	Leakage Current	< 0.7mA(240VAC)	
	Output	Constant Voltage	12VDC
Current Range		0-2.5A	0-1.25A
Rated power		30W Max.	
Voltage Accuracy		±5%	
Voltage Regulation		±1% @Full Load	
Load Regulation		±2%	
Hold-up Time		1s max.@Full Load	
Ripple& Noise *Note.2		≤±2%@Full Load,230VAC	
Output LF current ripple(<120Hz)		≤±1%	
Efficiency(Typ.)		≥83%	≥85%
Protection	Over Load Protection	105-150% Protection type: Auto Resume	
	Over Voltage Protection	> 12.6VDC	> 25.2VDC
	Short circuit Protection	Protection type: Auto Resume	
	Over Temperature protection	Protection type: Auto Resume	
Environment	Operating Temperature	-20°C...+45°C	
	tc	90°C	85°C
	Storage Temperature	-40°C...+60°C	
	Life time	> 50,000h@Full Load , 230V, ta=45°C	
	Temperature coefficient	±0.03%/°C(0-45°C)	
	Humidity	20%-90%RH	
Others	Dimension	261X30X17(LXWXH)mm	
Safety & EMC	Safety standards	EN 61347-1; EN61347-2-13; EN62493; EN62384	
	Withstand voltage	Input-Output : 3750V/5mA/1min	
	Isolation resistance	Input-Output : ≥4MΩ@500VDC	
	EMI	EN55015; EN61000-3-2 Class C; EN61000-3-3	
	EMS	EN 61547; EN 61000-4-2; EN 61000-4-5 —1000V;	
Note	1.All parameters NOT specially mentioned are measured at 230VAC input , full load and 25°C of ambient temperature. 2.Ripple & Noise are measured at 20MHz of bandwidth by using a 300mm twisted pair-wire terminated with a 0.1uF & 47 uF parallel capacitor.		

30W Constant Voltage Slim-US Series

US-30-XX LR1

Model list

No.	Model number	Input			Output		
		Voltage (VAC)	Current (A)	Frequency (Hz)	Constant voltage (VDC)	Normal working current (A)	P _{rated} (W)
1	US-30-12 LR1	220-240	0.24	50/60	12	0-2.5	30
2	US-30-24 LR1	220-240	0.24	50/60	24	0-1.25	30

Wiring diagram

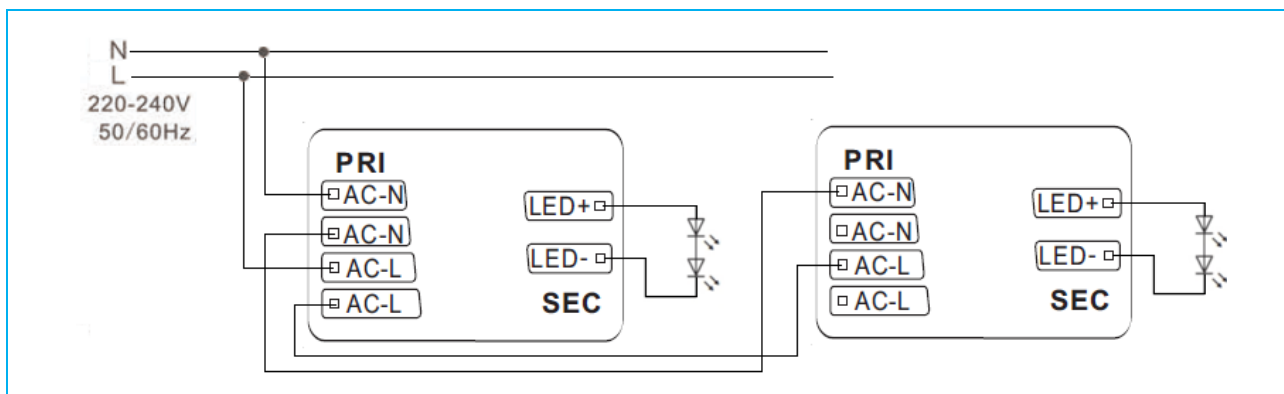

2D diagram

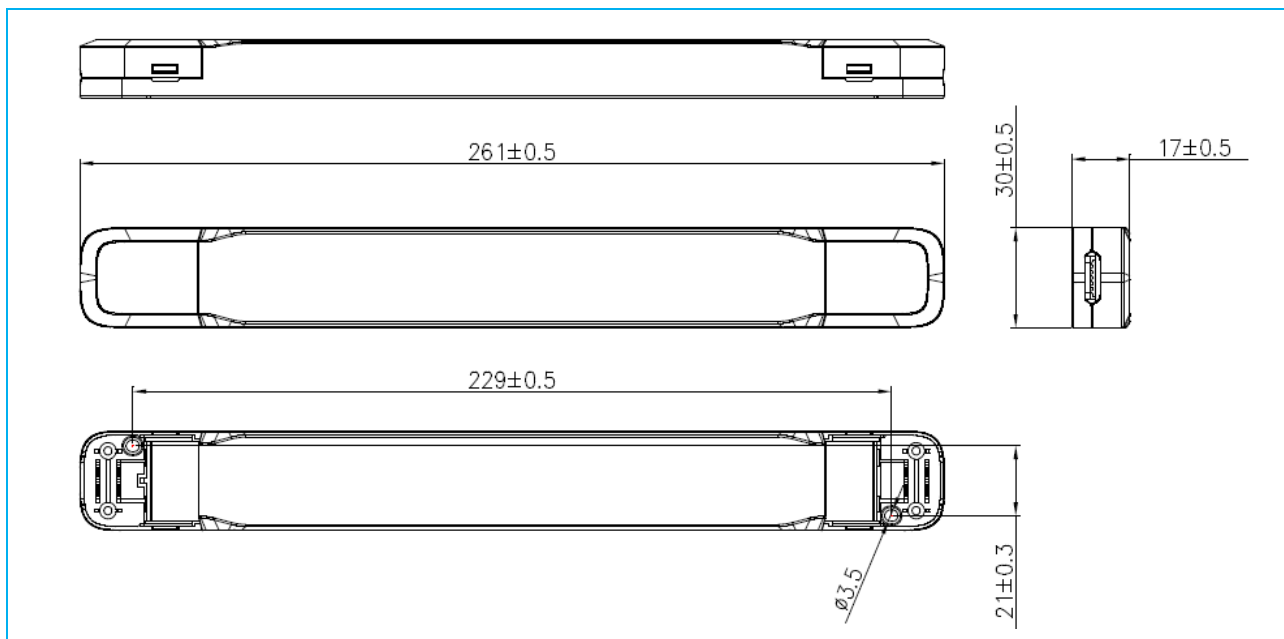

Curve@US-30-24 LR1

30W Constant Voltage Slim-US Series

US-30-XX LR1

Lifetime vs. Ambient Temperature Curve

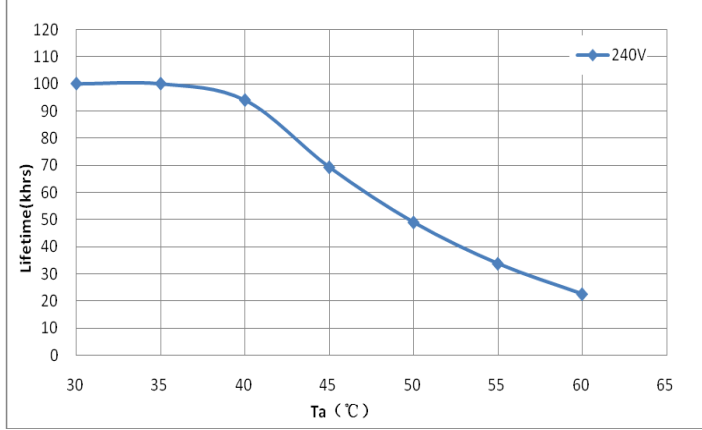

Efficiency vs. Load

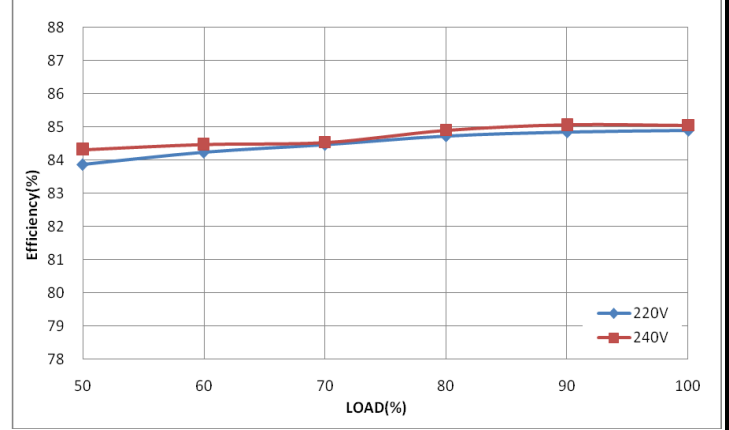

Power Factor Characteristics

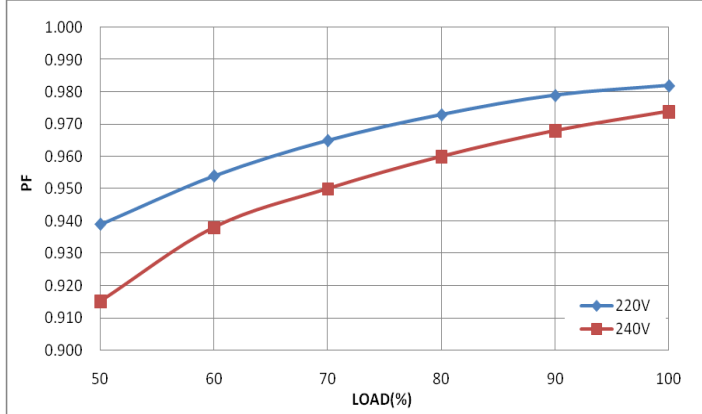

THD vs. Load

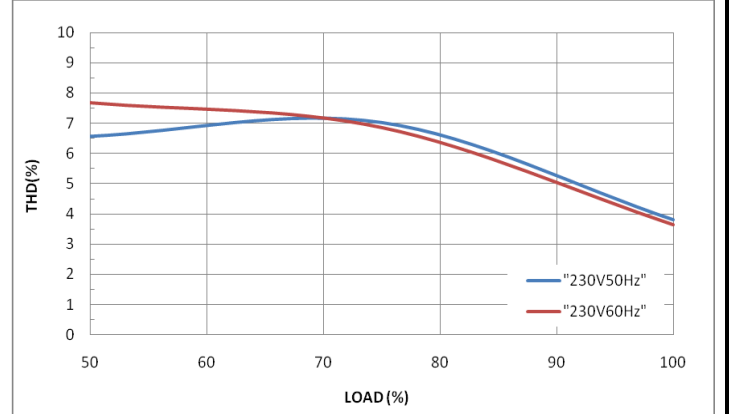

■ Operating window

